

Contents

Panel Mounted Pump System with UV Sterilization	2
Pressure Reducing Water System with Auto Flush	3
Animal Cage Rack and Hose Flushing Systems.....	4
Water Storage Tank Assemblies.....	5
Water Pressure Tank	6
Chlorinator	7
Reverse Osmosis System	8
Water Softening and Conditioning.....	9
Hoses	10
Quick Disconnects	10
Pumps	11
Solenoid Valves	12

Panel Mounted Pump System with UV Sterilization

Small footprint, panel mounted, self-contained system with pump, UV sterilizer and flow regulating valves for small facilities. When used with upgraded pump, system can be used with up to four pressure reducing panels to service mid-size applications. May be used with any size tank and combined RO water and chlorinator if required.

How it works

The system will continuously pump the water through the room distribution and return piping, passing through the UV bulb sleeve, removing contaminants, viruses and bacteria. The tank also contains a level sensor to determine if additional water is needed to replenish the supply. Fully automatic operation. Operates on 115 Volts AC Power.

Additional Features

- System includes flow regulators for system control, and isolation valves for system maintenance
- UV Controller pump includes monitor and counter
- UV bulb and sleeve can be changed or cleaned without draining the entire system
- Connect to new and existing valves and manifolds
- Monitor Pressure, Flow, UV light and Tank Level with Rees Scientific EMS
- Ideal for small facilities and minimal floor space required

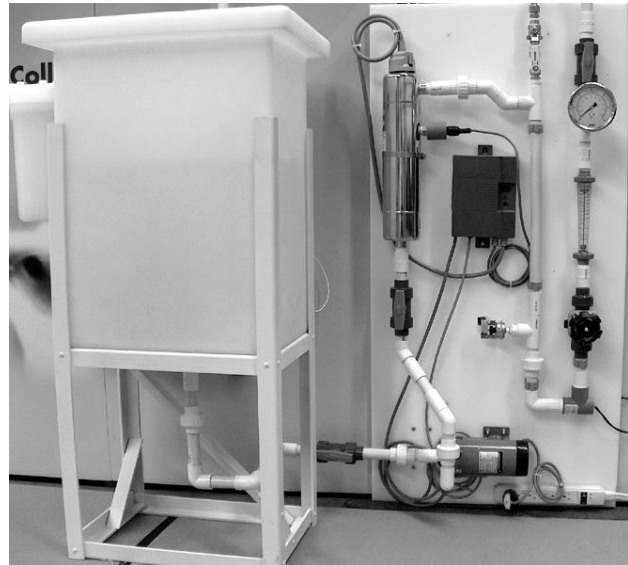

Available Options

- Back-up pump configuration
- Compact Tanks
- Cage Rack Flushing

Type	Part #
Recirculating Watering Pump System. Includes single 4.6 GPM pump, UV sterilizer, return water pressure regulating valve, pressure gauge, and sensors for flow, UV light, and pressure. For systems with water supply flowing from right to left.	W-PUMPSYS-1-L
Same as PUMPSYS-1-L but for systems with water supply entering flowing from left to right.	W-PUMPSYS-1-R
High capacity pump to allow panel mounted systems to support pressure reducing panel base systems.	W-PUMPUPGRD

Assemblies are mounted to 24" x 48" HDPE sheet for easy wall mounting and requires 115 VAC power.

*NOTE: Pump Systems will support up to 1000 ft of 3/4" pipe. Greater lengths of pipe will require additional pump assemblies.

All specifications are subject to change without notice.

Pressure Reducing Water System with Auto Flush

The Automated PRP (Pressure Reducing Panel) automates the flushing of rack manifolds and room distribution piping to avoid stagnation and to combat bacteria growth. This flushing process enhances water quality by bringing fresh water into the piping and flushing all of the potentially stagnant or contaminated water out of the system. Combining our output control capabilities with our pressure reducing panels, the Auto Flushing Pressure Reducing Watering System gives you the flexibility to schedule multiple flushing sequences per day, all performed automatically.



How it works

Flushing is initiated by actuation of solenoids installed at piping termination points. After a few minutes, the solenoid valve closes. The water is flushed from the manifolds through the drain lines to a nearby sink or drain.

Enjoy integration of Critical Monitoring, Alarming and Flush Control with Centron EMS

- Monitor Pressure and Flow
- Record flush event
- Program multiple flush sequences/schedule
- Optional Cage Rack flushing available
- Choose between PVC or Stainless Steel piping

Available Options

- Chlorinator
- RO System
- Water Filtration
- Mixing pumps
- Compact Tanks
- Cage Rack Flushing

Type	Part #
Pressure Reducing Panel with PVC Piping and Automatic Flushing. Includes surface mounted fiberglass enclosure, pressure regulators, flow switch and pressure sensor. Requires Microprocessor Controlled Flush Sequencer(s) listed below or Centron EMS output control(s). *NOTE: All wetted parts in Panel are Stainless Steel or PVC.	W-PRP-1

All specifications are subject to change without notice.

Animal Cage Rack and Hose Flushing Systems

Periodic flushing of cage rack piping, manifolds and recoil hoses helps to ensure animals are receiving clean drinking water. Our Automatic Flush Systems and Sanitizers utilize fresh or chlorinated water and clean, compressed air. Manual flush systems are also available.

Up to 8 cage racks can be flushed automatically using our Rack Flush Sequencer. All of our Recoil Hose Flush Systems can flush up to 6 recoil hoses at a time.

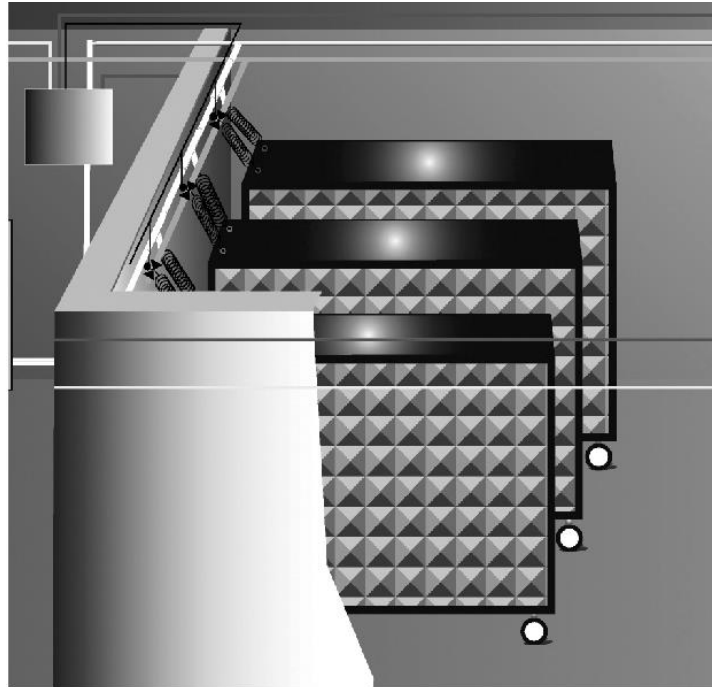

Type	Part #
Flush Solenoid. Stainless Steel Solenoid for use with Rack Flush Sequencer for Cage Rack Flushing. Requires 24v AC power. One Solenoid needed per rack.	W-FLUSH-SOL
Automatic Cage Rack Manifold and Recoil Hose Flush System and Sanitizer. Provides fully automated fresh water flush of cage rack manifolds. Includes microprocessor based Controller and on-board Air Compressor for evacuating water from manifold after final fresh water flush. Requires 115v AC power and connection to water supply.	W-RCK-SANITZR-F

All specifications are subject to change without notice.

Water Storage Tank Assemblies

Rees Scientific can offer a full range of water storage tanks in a variety sizes and capacities to fit your facility's needs. All of our tanks are made of Linear Polyethylene and are FDA approved for use with potable water. These rigid, self-supporting tanks have excellent resistance to chemicals, impact and abrasion. They withstand continuous operating temperatures up to 180 degrees F; intermittent service to 212 degrees F.



Specifications:

All water storage tank assemblies include

- Cover
- Intake water filter
- Float valve assembly
- Water level sensors
- All fittings and valves to connect tank to pump assembly.

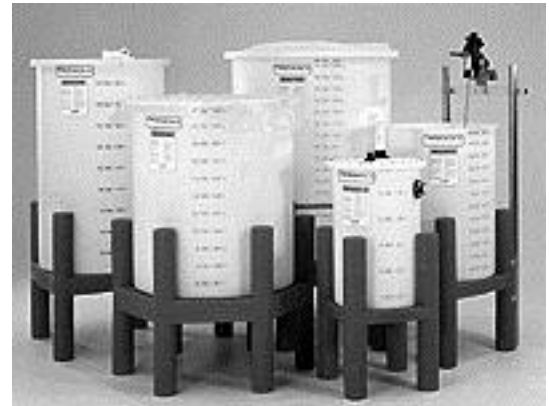

Optional tank stands available.

Capacity (gallons)	Dimensions (inches) w x h	Wall Thickness (inches)	Part #
55	24 x 36	1/4	W-TANK-55
120	29 x 50	1/4	W-TANK-120
250	38 x 50	5/16	W-TANK-250
500	50 x 74	3/8	W-TANK-500

If a specific size tank is required but not listed, RSC engineers can provide alternate sizes.

All specifications are subject to change without notice.

Water Pressure Tank

Adding a Water Pressure Tank to a Pressure Reducing Water System that includes water conditioning through Chlorination or Reverse Osmosis ensures that the proper flow of water is maintained throughout the system. The on-demand pump fills the diaphragm pressure tank from the water storage tank and provides a reserve of pressurized water. This reduces wear on the pump and provides a constant supply of water.

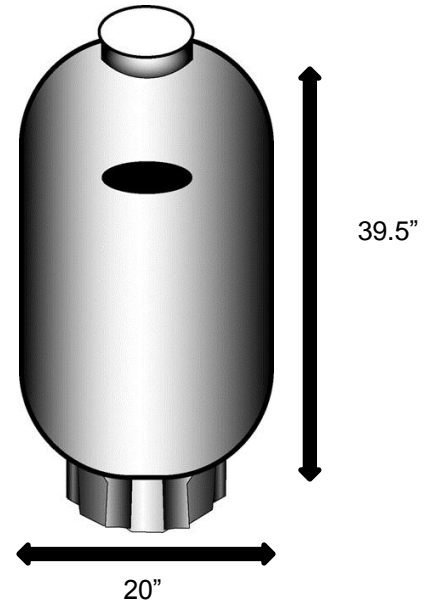

Specifications:

- **Inner Liner:** One-piece high density polyethylene
- **Outer Shell:** Fiberglass-wound & epoxy resin sealed
- **Air Cell:** Heavy mil ethyl-vinyl-acetate (EVA)
- **Upper & Lower Flanges:** Reinforced polypropylene
- **Base:** One-piece high density polyethylene
- **Service Connection:** Stainless steel
- **Air Valve:** Brass body, Schrader core assembly
- **Weather Cap:** High density polyethylene

Maximum Capacity /Equivalent Tank Size	Diameter x height (inches)	Wall Thickness (inches)	Draw down (Gallons)#			Connection size Female
			20-40	30-50	40-60	
35 gal/80 gal	20" x 39.50"	1/4	12.1	10.3	9.0	1"

Type	Part #
Water Pressure Tank. Includes Pump for use with Pressure Reducing Systems with Water Tanks when Chlorinator and/or Reverse Osmosis Water Maker is added to system.	W-PRES-TANK

All specifications are subject to change without notice.

Chlorinator

Rees Scientific's approach to Chlorination is different from any method used before in this industry. Rather than injecting chlorine into the system supply line, which can result in "clouds" of chlorine, or inaccurate control, Rees Scientific is using a batch method to chlorinate the supply water. Our chlorinator can maintain a user selectable level of Chlorine in the water supply tank, insuring the proper levels are reaching your valuable animals. The Rees Scientific Chlorinator is suitable for use with both circulating and pressure reducing systems, and can be retrofitted to any existing watering system, regardless of manufacturer.

Type	Part #
Chlorinator Unit automatically maintains a user selectable Chlorine level in Animal Drinking Water Supply Tank. Includes Free-Chlorine Sensor, pH Sensor, microprocessor based controller with display, mixing pump and associated piping for sensor suite. Requires Water Storage Tank and 115VAC power.	W-CHLORINATOR

Reverse Osmosis System

Reverse osmosis can remove dissolved minerals that cause hardness, toxic chemicals, and other impurities such as chromium, mercury and nitrates. It can improve the taste of your water, plus treated water will not produce a mineral build-up in pipes. Our Reverse Osmosis Systems remove 95-99% of most contaminants, providing a standardized water quality despite variations in location, water source and/or outside environmental factors such as weather conditions.

Rees Scientific uses RO systems by Millipore and Siemens sized to fit your application.



RO-600M
Produces 600 gallons of water per day

Performance Specifications
Inorganics.....up to 98% rejection
Organics.....> 99% rejection
Particulates> 99% removal
Bacteria< 5 CFU/ml
TOC< 0.1 ppm
Flow Rate0.416 gpm @ 77° F

Feed Water Parameters
Feed WaterPotable Cold
Maximum Fouling Index10
Maximum Conductivity1400 µS/cm
Maximum Free Chlorine< 0.5 ppm
Temperature.....34 - 95° F
Pressure (w/o Booster Pump)..... 60 - 90 psi

System Dimensions
H x W x D*18.2 x 16.2 x 8.3 inches
Weight25.4 lbs

*Does not include operating space requirements

RO-1000
Produces 1000 gallons of water per day

Performance Specifications
Inorganicsup to 98% rejection
Organics.....> 99% rejection
Particulates> 99% removal
Bacteria< 5 CFU/ml
TOC< 0.1 ppm
Flow Rate.....0.8 gpm @ 77° F

Feed Water Parameters
Feed Water.....Well or Softened
Maximum Fouling Index3 SDI
Maximum Free Chlorine< 0.02 ppm
Maximum Turbidity.....1 NTU
Temperature.....50 - 113° F
Inlet Pressure.....25 - 50 psi

System Dimensions
H x W x D*.....62 x 17 x 26 inches
Weight.....80 lbs

*Does not include operating space requirements

	Type	Part #
Millipore RiOs 100	Reverse Osmosis Water Maker. Produces 600 gallons of water per day. Includes pre-filter system to include 5 micron pre-filter and .25 cubic foot carbon tank. Requires 115v AC power.	W-RO-600M
Siemens	Reverse Osmosis Water Maker. Produces 1000 gallons of water per day. Includes 10" diameter multi-media sand filter, 9" diameter water softener filter, and 6" diameter exchange carbon filter. Requires 115v AC power.	W-RO-1000

All specifications are subject to change without notice.

Water Softening and Conditioning

According to the U.S. Geological Survey, more than 85 percent of the United States geography has hard water. Our Water Softening and Conditioning System purifies city or well water by removing the minerals that lead to lime scale buildup and hard water. Based on a detailed analysis of your water, individual components will be selected to properly condition your water supply. Includes sand and carbon filter systems.

Water Softeners are lightweight, with corrosion-resistant Fiberglass Reinforced Plastic (FRP) pressure vessel and cost-effective top mounted valve for commercial and light industrial applications.



Specifications:

- Fiberglass tanks are durable and corrosion-free
- Tank liners are blow-molded plastic wrapped in high-strength fiberglass and have epoxy resin for worry-free service
- Softeners include a motorized, 5-cycle control valve that is quiet, efficient and dependable
- Automatic regeneration controller is an electromechanical timer
- Duplex systems are available for applications that require a continuous supply of softened water
- Pretreatment lock-out switch assembly is included to deactivate downstream equipment during regeneration

Type	Part #
Water Softening/Conditioning System. Conditions city or well water. A detailed Water Analysis must be performed prior to final pricing to ensure selected components are suitable.	W-WATERSOFT

All specifications are subject to change without notice.

Hoses

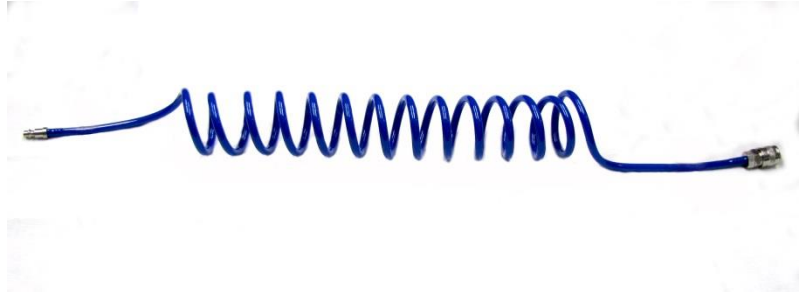

Type	Inside diameter	Material	Length	Part #
Recoil Hose for use with Animal Racks. Connects to Quick Disconnect on Room Piping	1/4"	Polyurethane (Kynar Optional)	6' Extended	W-RECOILHOSE-6
Recoil Hose for use with Animal Racks. Connects to Quick Disconnect on Room Piping.	1/4"	Polyurethane (Kynar Optional)	12' Extended	W-RECOILHSE-12
Quick Disconnect Hose for use with Primates. Hose has spiral wrapped, Stainless Steel protection.	1/4"	Kynar	6'	W-PRIMATEHOSE

Quick Disconnects

Quick Disconnect Assembly for Animal Racks. Used with Recirculating and Pressure Reducing Systems. One Disconnect needed per rack serviced by watering system.



Type	Part #
Quick Disconnect Assembly for Animal Racks. For use with 3/4" PVC in-room piping. Includes 3/4" PVC "T" fitting with Quick Disconnect pre-installed.	W-DISCONNECT-P
Quick Disconnect Assembly for Animal Racks. For use with 1/2" Stainless Steel in-room piping. Includes 1/2" Stainless Steel "T" fitting with Quick Disconnect pre-installed.	W-DISCONNECT-S

All specifications are subject to change without notice.

Pumps

Rees Scientific offers a range of pumps to meet your facility's needs. All of our pumps are non-metallic centrifugal pumps with alumina ceramic bearing materials and polypropylene. Totally enclosed, permanent split capacitor motors are compact, cool and economical. Pumps are impervious to chemicals such as chlorine or acid. Sizes to suit all applications. Recirculating Pump for use in Recirculating UV Sterilization System.

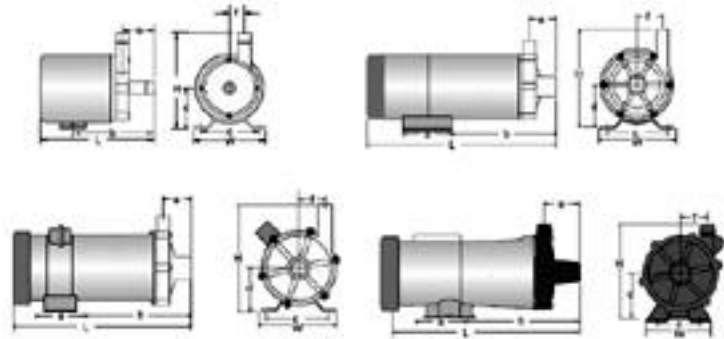

Type	Part #
Recirculating Pump. Requires 115VAC power.	W-PUMP
Single magnetic drive pump system with automatic controls for use with High Pressure Recirculating systems. Suitable for systems with up to 8 Pressure Reducing Panels and/or 1200 feet of PVC pipe. Pump has 1 HP motor and operates on 115 volts AC power. Other voltages and 3 phase motors available. Includes pump monitoring and automatic restart control panel. Pump runs continuously when in operation. Small footprint design for use in areas with limited space.	W-PUMP-HPR1
Single high capacity, magnetic drive, pump system with automatic start controls for use with High Pressure Recirculating systems. Suitable for systems with up to 16 Pressure Reducing Panels and/or 4000 feet of PVC pipe. Pump has 2 HP motor and operates on 208/220/440 volts, 3-phase. Pump runs continuously while in operation. Pump is high capacity, magnetic drive type.	W-PUMP-HPR1-3P
Dual magnetic drive pump system with automatic controls for use with High Pressure Recirculating systems. Suitable for systems with up to 8 Pressure Reducing Panels and/or 1200 feet of PVC pipe. Pump has 1 HP motor and operates on 115 volts AC power. Other voltages and 3 phase motors available. Includes pump monitoring and automatic restart control panel. Pump runs continuously when in operation. Small footprint design for use in areas with limited space.	W-PUMP-HPR2
Dual high capacity, magnetic drive, pump system with automatic start controls for use with High Pressure Recirculating systems. Suitable for systems with up to 16 Pressure Reducing Panels and/or 4000 feet of PVC pipe. Pump has 2 HP motor and operates on 208/220/440 volts, 3-phase. Pump runs continuously while in operation. Pump is high capacity, magnetic drive type.	W-PUMP-HPR2-3P

All specifications are subject to change without notice.

Solenoid Valves

For applications requiring a compact, cost effective and high pressure rated valve with extended cycle life. Typically used in Auto-Flushing systems. Unsurpassed performance in a compact plastic solenoid valve. High pressure ratings and considerable flow rates, and media separated design make this valve ideal for acids, caustics, solvents, chlorine solutions and ultra-pure liquids.



Specifications:

- Full vacuum through 70 PSI inlet, 60 PSI backpressure rating
- 0.63 Cv factor
- 2,000,000+ cycle life (tested under laboratory conditions)
- Continuous duty, NEMA 4X CSA approved coil
- 3/8" NPT fittings
- Elastomer seat seal in FKM (Viton®) or EPDM
- 24 volt AC operation

Features:

- Corrosion Resistant
- Continuous Duty
- Safe Operating Temp to 90° C
- NEMA 4x water and dust tight enclosure
- Moisture proof

Type	Part #
Solenoid Valve for end of line, high pressure and cage rack flushing	W-Solenoid

All specifications are subject to change without notice.