

Table of Contents-Main

V.2 Wireless..... 3-2

- V.2 Wireless Universal Transmitter 3-3
- V.2 Wireless Ambient Temp. & Relative Humidity Sensor Module 3-4
- V.2 Wireless USB Coordinator 3-5
- V.2 Net Wireless Coordinator 3-6

Version 1 Wireless..... 3-7

- Wireless Receiver-418 MHz 3-8
- Wireless Receiver-900 MHz 3-9
- Wireless Repeater 3-10
- Wireless RF-BUF 3-11
- Wireless 418 MHz Transmitter (Thermistor)..... 3-12
- Wireless Temperature and Relative Humidity Transmitter..... 3-13
- Wireless 418 MHz Transmitter (4-20mA) 3-14
- Wireless Sensor Analog 0-5V..... 3-15
- Wireless Options Europe..... 3-16
- Wireless Options Europe Con't 3-17

Table of Contents V.2

V.2 Wireless Universal Transmitter..... 3-3
V.2 Wireless Ambient Temp. & Relative Humidity Sensor Module 3-4
V.2 Wireless USB Coordinator 3-5
V.2 Net Wireless Coordinator 3-6

V.2 Wireless Universal Transmitter

Description

Utilizing Spread Spectrum technology at the transmitter level, Rees Scientific's New V.2 Wireless Monitoring System offers collision avoidance, receiver energy detection, link quality indication, clear channel assessment, acknowledgement and security.

Our new modules can monitor up to 4 inputs each (depending on model). When powered by the building's AC power, they serve as both transmitters and routers making this system less hardware intensive. Each module can buffer up to 7 days worth of data at a logging rate of every 5 minutes. Modules can support the entire range of Rees Scientific sensors.



Main Features

- All communications are Spread Spectrum for vastly enhanced communication reliability over older single channel 418 MHz transmission..
- Transmitters buffer 7 days of readings history recorded at 5 minute intervals.
- Most sensors in a typical install will be battery powered. Batteries last approximately 1 year in a 2.4 GHz system.
- Transmitters accept any type of Rees Scientific or industry standard input and provide 12 bit analog to digital conversion accuracy.
- 1 input, 2 input and 4 input transmitters available.
- Batteries are monitored in battery-powered units. Low batteries cause low battery alarms, which can dial out.
- Can be added to existing systems. A single system can contain wired sensors, Wireless Version 1 sensors, BACNet sensors and V.2 sensors.
- Dimensions (enclosure) 3.295 W X 3.295 H X 1.25 D (inches)
- FCC Certified- FCC ID: OUR-XBEE2*
- Transmit Power: +1dBm non-router mode
+3dBm router mode

Type	Order #
1 input	V2-U1
2 inputs	V2-U2
4 inputs	V2-U4
Optional AC Power Supply 6-9V DC 300mA	V2-TRANS
Replacement 3.6 Volt Battery	V2-BATT

Note: Requires Centron SQL Software Build 1012 or higher.

V.2 Wireless Ambient Temp. & Relative Humidity Sensor Module

Description

Utilizing Spread Spectrum technology at the transmitter level, Rees Scientific's New V.2 Wireless Monitoring System offers collision avoidance, receiver energy detection, link quality indication, clear channel assessment, acknowledgement and security.

Each module can buffer up to 7 days worth of data at a logging rate of every 5 minutes. Modules can support the entire range of Rees Scientific sensors. Also available with integrated light sensor.



Main Features

- Measures Ambient Temperature and Relative Humidity
- Also available with Integrated Light Sensor
- All communications are Spread Spectrum for vastly enhanced communication reliability over older single channel 418 MHz transmission.
- Buffers 7 days of readings history recorded at 5 minute intervals.
- Most sensors in a typical install will be battery powered. Batteries last approximately 1 year in a 2.4 GHz system.
- Batteries are monitored in battery-powered units. Low batteries cause low battery alarms, which can dial out.
- Can be added to existing systems. A single system can contain wired sensors, Wireless Version 1 sensors, BACNet sensors and V.2 sensors.
- Dimensions (enclosure) 3.295 W X 3.295 H X 1.25 D (inches)
- FCC Certified- FCC ID: OUR-XBEE2*
- Operating Temperature: -20° to 60° C
- Humidity: 0% to 100% RH non-condensing
- Transmit Power: +1dBm
+3dBm router mode

Type	Order #
Wireless Ambient Temperature Transmitter	V2-T
Wireless Ambient Temperature and Humidity Transmitter	V2-T/H
Wireless Ambient Temperature, Humidity, Light Transmitter	V2-T/H/L
Optional AC Power Supply 6-9V DC 300mA	V2-TRANS
Replacement 3.6 Volt Battery	V2-BATT

Note: Requires Centron SQL Software Build 1012 or higher.

3-4

V.2 Wireless USB Coordinator

Description

The V.2 Wireless USB Coordinator serves as end-point for the V.2 wireless network. It is connected to the Rees Scientific Centron, Satellite or Virtual Node via USB and relays the transmissions from all V.2 wireless sensors to the node.



Main Features

- Connects Directly to Rees Scientific Centron, Satellite or Virtual Node via USB port.
- Picks up signal from V.2 transmitters.
- Receives power from Node. Reduces Node battery backup time to approximately 3.5 hours.
- Transmit Power: +3dBm

Type	Order #
V.2 Wireless USB Coordinator	V2-CRD

Note: Requires Centron SQL Software Build 1012 or higher.

V.2 Net Wireless Coordinator

Description

A 4 hour battery backed up network device that will connect V.2 transmitters at remote sites back to a central node over the organization's existing TCP/IP Network. Requires IP address.

Easily monitor sensors on the other side of your facility, across campus, or across country.



Main Features

- 4 hour battery backup
- LED indicator light
- Connects directly to TCP/IP network
- Dimensions (enclosure) 4.625 W X 4.625 H X 2 3/8 D (inches)
- FCC Certified-FCC ID: OUR-XBEE2*
- Transmit Power: +3dBm

Type	Order #
V.2 Net Wireless Coordinator	V2-NET

Note: Requires Centron SQL Software Build 1012 or higher

Table of Contents

Wireless Receiver-418 MHz	3-8
Wireless Receiver-900 MHz	3-9
Wireless Repeater	3-10
Wireless RF-BUF	3-11
Wireless 418 MHz Transmitter (Thermistor)	3-12
Wireless Temperature and Relative Humidity Transmitter	3-13
Wireless 418 MHz Transmitter (4-20mA)	3-14
Wireless Sensor Analog 0-5V	3-15
Wireless Options Europe	3-16

Wireless Receiver - 418 MHz

Description

This 418 MHz Wireless Receiver from Rees Scientific receives CRC-16 error-checked data packets from Rees Scientific RF sensors and makes the information available to the Centron and e-Centron hardware and software. Each receiver is powered and battery backed up by the node. The receiver can be wall mounted or installed above conventional drop ceilings.



The RF-418 will work with new and existing Rees Scientific monitoring systems, giving users the flexibility of going totally wireless or expanding existing hardwired systems with wireless sensors.

Main Features

- High performance 418 MHz receiver.
- Serial connection directly to a Centron, e-Centron or Satellite
- Powered by RS232 port or external source.
- ASCII radio packet data output.
- Decodes CRC-16 error encoded radio packets.

Type	Order #
418 MHz Wireless Receiver for Wireless Sensors, Connect Directly to Centron or Satellite	RF-418

900MHz Receiver

Description

The Rees Scientific RF-900 is a 900 MHz Wireless Receiver that receives CRC-16 error-checked data packets from Rees Scientific RF-Repeaters and RF sensors. The RF 900 uses Spread Spectrum technology to scan the 900MHz range for an open channel. Using the 900 MHz frequency allows us to employ repeaters that will receive the 418 MHz data packets from our sensors and forward to the next repeater or 900MHz receiver for communication with the node. The RF-900 receiver passes along the data and makes the information available to the Centron and e-Centron hardware and software. Each system or node will require one receiver and can be wall mounted or installed above conventional drop ceilings.



The RF-900 will work with new and existing Rees Scientific monitoring systems, giving users the flexibility of going totally wireless or expanding existing hardwired systems with wireless sensors.

Main Features

- LED power and configuration activity indicator
- Reverse Polarity SMA 6.5" Antenna
- High Impact ABS enclosure
- Channel Capacity hops through 25 channels, Up to 65,000 NetIDs
- Serial Data Interface (RS-232), 5V, 3.3V tolerant
- I/O Data Rate - 9600 or 19200 bps
- Transport Protocol - Transparent networking
- Transmit Power Output - 100mW
- Interference Rejection - 70 dB at pager and cellular phone frequencies

Type	Order #
900 MHz Frequency Hopping Transceiver - Connect Directly to Centron or Satellite. Picks up Repeater Signals	RF-900

Wireless Repeater

Description

The Rees Scientific RF-Repeater is a 418 MHz Wireless Receiver with an integrated 900 MHz transceiver. The unit receives CRC-16 error-checked data packets from Rees Scientific RF sensors within its ranges and re-transmits the data at 900 MHz to our RF-900 receiver. RF-Repeaters help to extend the range of sensors and are needed when sensors are located on multiple floors or when building construction limits the range of the sensors. The RF-Repeaters can work in succession allowing you to extend the range of the sensors.



Main Features

- 418 MHz Receiver with 900 MHz spread spectrum transceiver Mesh Repeater
- As many as 26 layers of Mesh Network repeating
- Automatic randomization and collision avoidance
- Built in 100 milliwatt 900 MHz frequency hopping radio for long-range wireless interface
- Low power, 6-24 VDC at 200 milliamp transmitting, 80 milliamp receiving
- Supports all Rees Scientific Sensors (Temperature, Humidity, Analog, Pressure, Light level) transmitters
- Reverse Polarity SMA connection with external antenna
- 3.3 X 3.3 X 1.4 inch ABS enclosure with flange mounts

If a RF-Repeater is needed, users will also need an RF-900 receiver.

Type	Order #
900 MHz Frequency Hopping Transceiver - Connect Directly to Centron or Satellite. Picks up Repeater Signals	RF-RPTR
Battery Backup for Receivers and Repeaters. Provides approx. 4 Hour Backup.	RF-BATT-BACK

Wireless RF-BUF Series

Description

The Rees Scientific RF-BUF Series is a set of transceivers with data buffering capabilities. These devices allow you to add wireless sensors to a node located in another room, building or campus by routing the data to the node over your existing TCP/IP LAN/WAN infrastructure. Up to 11 RF-BUF devices can be connected to a single node. One device can be connected directly to a node (in lieu of a regular receiver using null modem serial cable #RF-NUL-CBL) allowing data buffering protection if the Node were to go off line. Data from the sensors is collected by the RF-BUF device and transmitted to the node. If the device loses communication with the node these units can store data on up to 96 points logging every 5 minutes for 4.4 days. Fewer points and/or lower logging rates will extend the number of days of data stored ensuring that data is not lost if the network or node goes offline.

These devices include a 24 hour battery backup and are available in 418MHz and 900MHz frequencies for US installations and 433MHz and 2.4GHz frequencies for European installations.

Note: CentronSQL software and network connection are required.

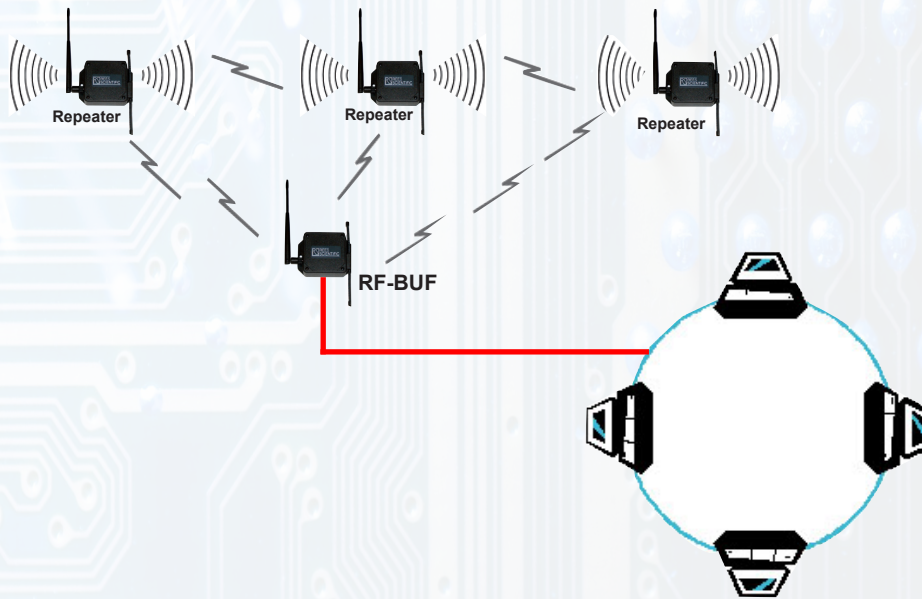

Type	Order #
418MHz transceiver with data buffering capabilities	RF-418-BUF
900MHz transceiver with data buffering capabilities	RF-900-BUF
433MHz transceiver with data buffering capabilities for European wireless sensors	RF-433-BUF-EV
2.4GHz transceiver with data buffering capabilities for European wireless sensors	RF-2.4-BUF-EV
Null Modem serial cable	RF-NUL-CBL

418 MHz Transmitter

Description

The **Rees Scientific Sensor Thermistor** wireless transmitter is a battery operated 10K thermistor interface with a microprocessor controlled 418 MHz. FCC certified radio transmitter. The Sensor has an on board time of day clock that allows it to spend most of the time in a low power quiescent state. At predetermined time intervals the clock will wake up the onboard microprocessor. Unique serial number information is read from a Dallas Semiconductor 1-wire digital device and thermistor data is read from a 12-bit analog to digital converter. This information is combined with a CRC-16 error check and transmitted in a very short data packet that results in a transmitter on time of only 15 milliseconds. This architecture allows the Sensor to consume very low energy resulting in a battery life of up to 10 years.



The electronics are coated with a conformal material that provides a moisture barrier against condensation. Submersion in water is not recommended. An external pushbutton in the top ABS cover activates the service switch. The Sensor is shipped with the transmitter turned off (anytime the Sensor is to be shipped the transmitter should be turned off or must be placed in a shielded container to prevent interference that might cause shipping problems). Start the Sensor by momentarily pushing the service switch. When the service switch is pushed a data transmission occurs immediately and a special mark is introduced in the ID field of the transmitted data packet to indicate which sensor is in service or installation. The service switch is also used to put the Sensor in a quiescent mode (no transmissions and very low power consumption). This is the state the Sensor is in when you receive it from the manufacturer. Push and hold the service switch for 5 seconds or more to enter this powered down state.

Main Features & Technical Features

- 10K thermistor transmitter
- Transmits unique ID and thermistor data
- Transmission rates from 10 to 17 seconds random
- Up to 100 transmitters can coexist
- Battery lasts from 6 to 10 years
- Very small (1.3" X 2.1" X .6") ABS Enclosure
- Complies with part 15 of the FCC rules
- Water resistant coating on PCB
- CRC-16 checked Status, ID, and thermistor data
- Internal Loop antenna

PARAMETER	UNITS
Shelf life with battery installed	10 Years in quiescent mode
Dimensions (enclosure)	1.5 W X 2.1 H X .6 D (inches)
Weight	1.5 oz.
Operating Temperature	-40° to 85° C
Humidity	0% to 90% non-condensing
Battery life with transmissions	6-10 years with tx period of 10-17 seconds random
Battery	3.6 volt ½ AA Lithium
FCC Certified	FCC ID: M5ZWOWANA

Type	Range	Order #
Wireless Ambient Air Sensor - Type 2	-15 to +60C	TPT2A-RF
Wireless Temperature Probe - Type 2	-15 to +60C	TPT2-RF
Wireless Temperature Probe - Type 3	-50 to +10C	TPT3-RF
Wireless Temperature Probe - Type 4	-80 to -10C	TPT4-RF
Wireless Cryogenic Thermistor Probe	-200 to -125C	CRYO6-RF*

**See Cryogenic Thermistor Probes in Sensors section of catalog.*

Wireless Temperature and Relative Humidity Transmitter

Description

The Rees Scientific Wireless Temperature and Relative Humidity sensor is a battery operated temperature and relative humidity sensor with a microprocessor controlled 418 MHz. FCC certified radio transmitter. It has an on board time of day clock that allows it to spend most of the time in a low power quiescent state. At predetermined time intervals the clock will wake up the onboard microprocessor. Unique serial number information digital temperature and relative humidity data are read from the digital temperature sensor and the relative humidity sensors. This information is combined with a CRC-16 error check and transmitted in a very short data packet that results in a transmitter on time of only 15 milliseconds. This architecture allows the Sensor to consume very low energy resulting in a battery life of up to 3 years.



The electronics are coated with a conformal material that provides a moisture barrier against condensation. Submersion in water is not recommended. When the service switch is pushed a data transmission occurs immediately and a special mark is introduced in the ID field of the transmitted data packet to indicate which sensor is in service or installation.

Main Features

- Measures Temperature and Relative Humidity
- Battery life up to 3 years
- Very small (1.3" X 2.1" X .6") ABS Enclosure
- Broad operating temperature range
- Complies with part 15 of the FCC rules
- Water resistant coating on PCB
- Internal Loop antenna

Technical Features

PARAMETER	UNITS
Dimensions (enclosure)	1.5 W X 2.1 H X .6 D (inches)
Weight	1.5 oz.
Storage Temperature	-40° to 70° C
Operating Temperature	-40° to 70° C
Humidity	0% to 100% non-condensing
Battery life with transmissions	2-5 years with tx period of 10-17 seconds
Battery	3.6 volt Lithium
FCC Certified	FCC ID: M5ZWOWTHL

Type	Order #
Wireless Ambient Temperature and Humidity Transmitter	RF-T/H

418 MHz Transmitters

Description

The Rees Scientific 4-20 MA wireless transmitter that allows RSC to connect to an industry standard sensor, such as an RTD temperature sensor or differential pressure sensor, to a wireless system. Because the 4-20 MA sensor often requires more power, this solution is sold with a standard 110 volt to 24 volt DC wall transformer.



Sensors that the Transmitter works with:

- RTD Temperature Sensors
- Differential Pressure Sensors
- Flow Sensors
- Shaker Sensors
- Humidity Sensors
- CO 2 Sensors
- Oxygen Sensors

Main Features & Technical Features

- Analog input used when connecting an industry standard 4-20 MA sensor (example, RTD) to a wireless system.
- 12-bit Analog to Digital Conversion
- Transmits Unique ID and analog value
- Transmission intervals from 10 to 17 seconds random
- Battery life up to 3 years
- Very small (1.3" X 2.1" X .6") ABS Enclosure
- Complies with part 15 of the FCC rules
- Water resistant coating on PCB
- Internal Loop antenna

PARAMETER	UNITS
Transmission rate	10-17 seconds random
Dimensions (enclosure)	1.5 W X 2.1 H X .6 D (inches)
Weight	1.5 oz.
Operating Temperature	-40° to 85° C
Input	121 Ohms, 0-20.66 milliamp. 12-bit resolution, 20 mA=3965
Humidity	0% to 90% non-condensing
Battery life with transmissions	2-5 years with tx period of 10-17 seconds
Battery	3.6 volt Lithium
FCC Certified	FCC ID: M5ZWOWANA

Type	Order #
Wireless 4-20 mA Input. Includes Wall Transformer to Supply 12V Loop Power for the Sensor. Sensor must be purchased separately.	RF-4-20

Sensor Analog 0-5V

418 MHz transmitters with analog input and Unique ID

Description

The Rees Scientific Analog 0-5V wireless transmitter is a battery operated 12 bit analog-to-digital converter designed to interface with existing alarm contacts. The sensor sends CRC-16 error check data packets that are received by the RSC receivers and repeaters.

The electronics are coated with a conformal material that provides a moisture barrier against condensation. Submersion in water is not recommended.



Main Features

- Analog input – Used when taking alarm contacts from existing freezers, incubators or LN2 freezers.
- 12-bit Analog to Digital Conversion
- Transmits Unique ID and analog value
- Battery life up to 3 years
- Very small (1.3" X 2.1" X .6") ABS Enclosure
- Complies with part 15 of the FCC rules
- Water resistant coating on PCB
- Internal Loop antenna

Technical Features

PARAMETER	UNITS
Transmission rate	10-17 seconds random
Dimensions (enclosure)	1.5 W X 2.1 H X .6 D (inches)
Weight	1.5 oz.
Operating Temperature	-40° to 85° C
Input	100k Ohms, 0-5 volts. 12-bit resolution, 5 VOLT=4096
Humidity	0% to 90% non-condensing
Battery life with transmissions	2-5 years with tx period of 10-17 seconds
Battery	3.6 volt Lithium
FCC Certified	M5ZWOWANA
Weight	1.5 oz.

Type	Order #
Wireless 0-5 volt Input. Does not provide power for the Sensor. Sensor must be purchased separately.	RF-0-5

Wireless Options Europe

Type	Order #
2.4 GHZ wireless receiver for Europe. Requires minimum of 1 RF-RPTREV (repeater) to receive signals from sensors.	RF-2.4EV

Type	Order #
Wireless repeater for Europe. The number of Repeaters needed for the job and specified for this line item is APPROXIMATE. If more are needed, they will be added free of charge. If fewer are needed, they will not be supplied, and credits will not be issued. NOTE: Unit is not battery-backed up and requires purchase of RF-BATT-BACKEV.	RF-RPTREV

Type	Order #
Battery Backup for Receivers and Repeaters. Provides approx. 4 Hour Backup.	RF-BATT-BACK-EV

Type	Order #
Network Connection for RF-2.4 EV- Couples Receiver to Centron, Satellite, via TCP/IP.	RF-NET-EV

Type	Order #
Wireless 0-5 volt Input. Does not provide power for the Sensor. Sensor must be purchased separately.	RF-0-5-EV

Type	Order #
Wireless Ambient Temperature and Humidity Transmitter	RF-T/H-EV

Type	Order #
Wireless 4-20 mA Input. Includes Wall Transformer to Supply 24V Loop Power for the Sensor. Sensor must be purchased separately.	RF-4-20-EV

Type	Order #
Wireless light sensor for Europe. Detects lights on/off condition.	RF-LIGHTEV

continued on next page

Wireless Options Europe

Type	Order #
Wireless Transmitter for use with Dry Contact Switches.	RF-SWITCHEV

Type	Range	Order #
Wireless Ambient Air Sensor - Type 2	-15 to +60C	TPT2A-RF-EV
Wireless Temperature Probe - Type 2	-15 to +60C	TPT2-RF-EV
Wireless Temperature Probe - Type 3	-50 to +10C	TPT3-RF-EV
Wireless Temperature Probe - Type 4	-80 to -10C	TPT4-RF-EV
Wireless Cryogenic Thermistor Probe	-200 to -125C	CRYO6-RF-EV*

**See Cryogenic Thermistor Probes in Sensors section of catalog.*